性能优势 PERFORMANCE ADVANGATE

1. 波纹管是波纹管阀门的关键组件，采用自动滚焊，焊在阀瓣与阀杆上，确保阀杆部件100%零泄露。
Bellow is the key part of bellows valves, which is welded to both the valve bonnet and valve stem, with automatic roll welding. The metal bellow can keep the stem part 100% no leakage.
2. 双密封设计（波纹管+填料）。波纹管形成第一道金属密封防止泄漏，如果波纹管失效，填料可以提供第二道密封。
Double seal design (bellows+packing). Bellow form a metal seal to prevent leakage, and packing can provide seal if the bellow failed.
3. 堆焊阀座，即使在恶劣工况下，也能确保可靠的密封。
Overlay welded seat can keep reliable sealing under severe conditions.
4. 人体工程学设计手轮，使用寿命更长，操作轻松便捷且安全可靠。
Ergonomic hand wheel. It provide longer service life and easier Operation

技术规范 TECHNICAL SPECIFICATION

设计标准 Design standard: DIN EN 13709:2003
 结构长度 Face to face dimension: DIN EN 558-1:1995
 连接法兰 Flanged ends: DIN EN 1092-1:2002
 对焊连接 Welded ends: DIN EN 12627
 试验与检验 Test & inspection: DIN EN 12266:2003

应用 APPLICATION

热油系统、蒸汽系统、冷热水系统等等
 Thermal oil system, steam system, hot and cold water system etc.

产品零部件材料 PRODUCT PARTS AND MATERIALS

序号/No.	零件名称 Parts Name	材质 Materials		
1	阀体 Body	GS-C25/1.0619	CF8/1.4301	CF8M/1.4408
2	阀瓣 Disc	A105+13CR	SS304	SS316
3	阀杆 Stem	X20Cr13	SS304	SS316
4	波纹管 Bellows	SS304/SS316/SS321/SS316Ti	SS304/SS316/SS321/SS316Ti	SS316/SS321/SS316Ti
5	垫片 Gasket	Graphite+SS	Graphite+SS	Graphite+SS
6	螺母 Nut	A194 2H	A194 8	A194 8M
7	螺栓 Bolt	A193 B7	A193 B8	A193 B8M
8	填料 Packing	Graphite	Graphite	Graphite
9	压盖 Gland	Steel	Steel	Steel
10	阀盖 Bonnet	GS-C25/1.0619	CF8/1.4301	CF8M/1.4408
11	定位片 Guide piece	C.S	C.S	C.S
12	阀杆螺母 Stem nut	Steel	Copper alloy	Copper alloy
13	手轮 Hand wheel	Steel	Steel	Steel
14	螺帽 Lock nut	A105	Steel	Steel

备注Notes: 以上零件为常规产品材质，如有特殊要求，可根据客户要求变动，如密封面为司太立。
 Above parts materials are used for conventional product. If there are special requirements, which can be changed according to customer requirements. For example, the sealing can be Stellite.

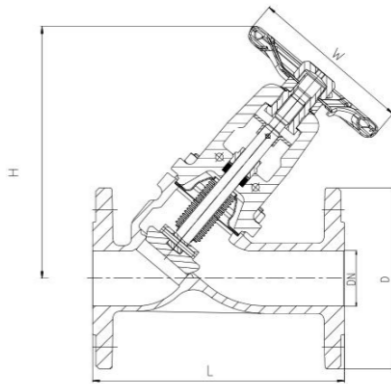

主要连接尺寸 MAIN DIMENSIONS(mm)

Fig.VK611 PN16																
口径 Size DN	15	20	25	32	40	50	65	80	100	125	150	200	250	300	350	400
总长 L RF/BW	130	150	160	180	200	230	290	310	350	400	480	600	730	850	980	1100
外圆 D	95	105	115	140	150	165	185	200	220	250	285	340	405	480	520	580
手轮 W	140	140	160	160	180	200	220	250	300	350	400	450	550	600	700	700
中心高 H	192	192	207	207	245	253	295	328	385	427	480	672	775	852	1005	1140
重量 Weight(kg)	4	4.8	5.8	7.8	9.5	12.5	17	22	36	52	81	135	240	305	510	740
行程 Stroke	8	8	10	10	12	15	17	22	28	34	40	60	75	85	100	110
流量 Kvs(m3/h)	4.2	7.4	12	19	30	47	77	120	188	285	410	725	1140	1660	2230	2950
Fig.VK612 PN25																
口径 Size DN	15	20	25	32	40	50	65	80	100	125	150	200	250	300	350	400
总长 L RF/BW	130	150	160	180	200	230	290	310	350	400	480	600	730	850	980	1100
外圆 D	95	105	115	140	150	165	185	200	235	270	300	360	425	485	555	620
手轮 W	140	140	160	160	180	200	220	250	300	350	400	450	550	600	700	700
中心高 H	192	192	207	207	245	253	295	328	385	427	480	672	775	852	1005	1140
重量 Weight(kg)	4	4.8	5.8	7.8	9.5	12.5	17	22	37	53	82	140	245	315	530	760
行程 Stroke	8	8	10	10	12	15	17	22	28	34	40	60	75	85	100	110
流量 Kvs(m3/h)	4.2	7.4	12	19	30	47	77	120	188	285	410	725	1140	1660	2230	2950
Fig.VK613 PN40																
口径 Size DN	15	20	25	32	40	50	65	80	100	125	150	200	250	300	350	400
总长 L RF/BW	130	150	160	180	200	230	290	310	350	400	480	600	730	850	980	1100
外圆 D	95	105	115	140	150	165	185	200	235	270	300	375	450	515	580	660
手轮 W	140	140	160	160	180	200	220	250	300	350	400	450	550	600	700	700
中心高 H	192	192	207	207	245	253	295	328	385	427	480	672	775	852	1005	1140
重量 Weight(kg)	4	4.8	5.8	7.8	9.5	12.5	17.5	23	38	54	83	142	260	320	560	790
行程 Stroke	8	8	10	10	12	15	17	22	28	34	40	60	75	85	100	110
流量 Kvs(m3/h)	4.2	7.4	12	19	30	47	77	120	188	285	410	725	1140	1660	2230	2950